

A Little Gem for QRP

*The T2FD antenna thinks it's a full-size rhombic.
Feeding is believing.*

W. Brandon Randolph W8VFT
895 Clifton Road
Xenia OH 45385

While much has been written about antennas in general, little has been published about outstanding radiators for serious QRP work. From reading some of the journals, one would think that QRP is illegitimate unless transmitted from a dipole buried in the basement. Since I do not subscribe to the premise that a second-rate antenna is required to operate QRP, I

constructed a QRP version of W3HH's T2FD antenna. This little gem is a real performer, and I would like to share with you the plans for its construction.

For those not familiar with the antenna, a little history is in order. T2FD means terminated folded dipole. This antenna reminds me of a folded-back terminated rhombic. The initial data appeared in *QST* in June, 1949. The next article appeared in *CQ* in November, 1951. *CQ* also published a book called *Antenna Roundup* in 1963. It contained two very informative articles on this antenna.

I constructed one of these antennas prior to the Xenia, Ohio, tornado in April, 1974. I was using a custom-made high-power terminating resistor, and since it could not be replaced, I did not consider rebuilding this antenna after it was destroyed. By the time we moved to the country, I had forgotten how well this antenna performed.

After moving to the country, we installed a wind-powered electric system, and QRP seemed very appropriate. After optimizing our electric system, I was not willing to operate with a second-rate antenna.

After looking through several antenna books, I ran across my old friend T2FD. The terminating resistor has always been the difficult item to obtain. Since I wanted to operate with five Watts, I figured it should be easy to parallel two-Watt carbon resistors for any value I needed. This was the birth of my QRP T2FD.

The antenna is configured as a sloping folded dipole. One end of the antenna is attached at an appropriate height on a tower or pole and the other end can be tied to a fence post or what have you. In the drawing, you will notice that it is fed with 300-Ohm TV-type rib-

bon. This antenna can be fed with other impedance lines, but it is beyond the scope of this article to cover all possible designs. If 300-Ohm feedline is not acceptable, I would suggest you research the previously-mentioned articles for complete design information. I chose 300-Ohm feedline because it was cheap and readily available.

Constructing the Terminating Resistor

For 300-Ohm feedline, the terminating resistor is a rather critical 390 Ohms. It just so happens that ten 3900-Ohm, two-Watt resistors in parallel will give us 390 Ohms at a 20-Watt rating. So far, so good. A 1-1/8-inch hole saw will cut two circles in a piece of circuit board faster than I can describe it. These two circles will form the end plates for a resistor cluster pack. Holes are drilled through the board so that three resistors are centered around the middle of the circle. Then the remaining seven resistors are equally distributed around the circumference. This procedure is repeated on the other end plate. When all the resistors are properly aligned with the copper side of the circuit board facing away from the

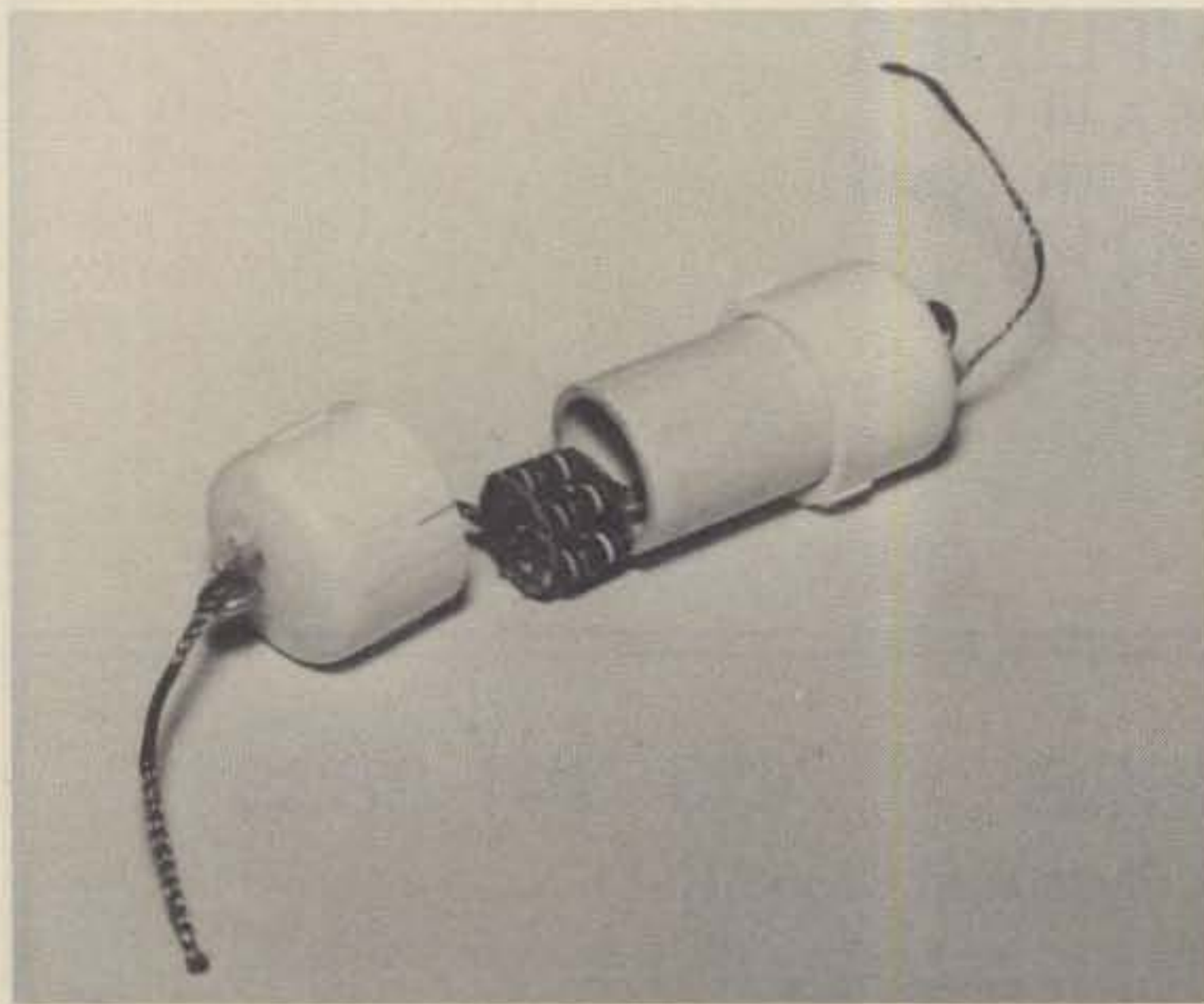

The terminating-resistor assembly.

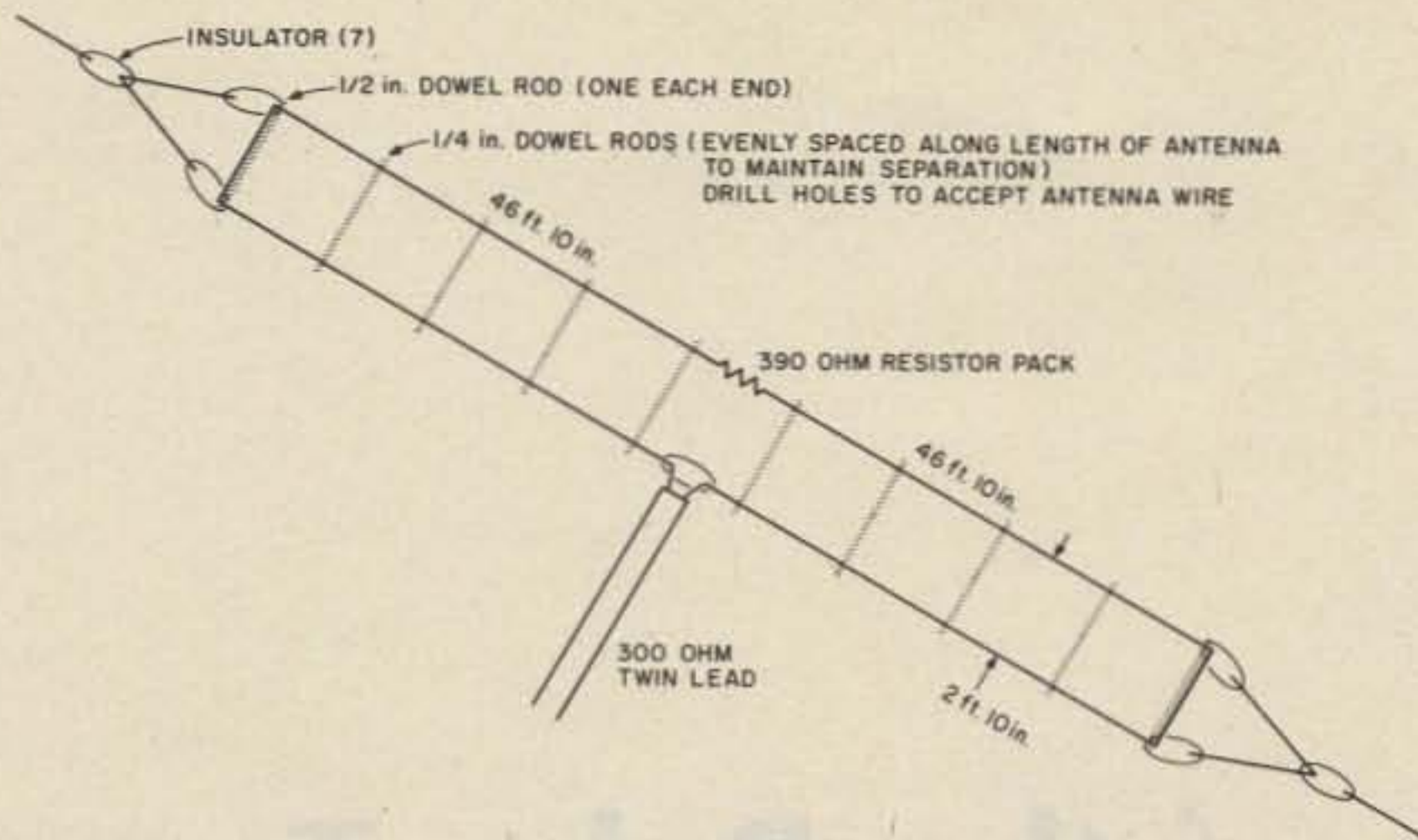

Fig. 1. 80-meter version of the T2FD antenna.

resistors, the assembly may be soldered. The result will be ten resistors wired in parallel.

This resistor pack will now have to be weather-proofed. The following materials will be needed: one piece of PVC pipe 3½" long and 1¼" in diameter; two 1¼" PVC end caps; two screw eyes with lock washers and nuts; two large flat washers that will just fit inside the end caps; two nine-inch-long pieces of ¼" tinned braid; one tube of GE silicone rubber cement; and a small can of PVC pipe cement.

Drill a hole through the center of the pipe caps. Drill a second hole next to this center hole. This second hole is where the braid will come through. Thread the braid halfway through the second hole. Insert the eyebolt through the center hole. Now put the large flat washer inside the pipe cap, bringing the braid out around the inside. Slip on the lock washer and nut and tighten down the assembly. A little silicone rubber cement will waterproof the hole where the eyebolt and braid come through the end cap. Repeat the procedure for the other end cap and allow both ends to dry.

The next step is to trim the braid on the inside of the end caps to the shortest length that can be readily soldered to the copper foil

of the resistor pack. Solder the braid of the other end cap to the other end of the resistor pack. Cement both ends of the PVC pipe liberally and shove the assembly together. Allow it to dry while you work on the remainder of the antenna.

Sticks and Stuff

Since the antenna is for 80 meters, the total length is a little over 90 feet. Separators must be used to keep the antenna aligned. Eight wooden dowel rods 3 feet long and ¼ inch in diameter will fill the bill. For the end separators, we will need two dowels 3 feet in length but ½ inch in diameter. Five small porcelain insulators will be needed, one for the center and two at each end. Plastic separators would be preferable but wooden dowel rods that have been soaked in oil will weather reasonably well.

The two sides of the dipole must be separated by 2 feet 10 inches. This makes it easy using the 3-foot rods. Measure back one inch from each end and drill your holes. These holes should be drilled before the rods are soaked in oil.

Bits and Pieces

The assembly of the wire part of the antenna should be apparent from the drawing. The wire should be cut to the correct length each side of center, and the sepa-

rators should be threaded on the wire. When this is completed, the center insulator and terminating resistor can be installed. The braid coming through the end caps should be soldered to the antenna wire connected to the eyebolts. This will make a good electrical connection from the resistor pack to the antenna while the eyebolt will take the weight of the antenna off the internal resistors. The 300-Ohm lead-in wire should now be soldered to the center insulator feedpoint.

We are now ready to pull the antenna up into position. It does not matter how the antenna is oriented with reference to the ground. It will probably lie horizontally. This is not important to its operation, but it should slope toward the ground at about a 30-degree angle. This antenna does not require much real estate and should be popular with those living in the city.

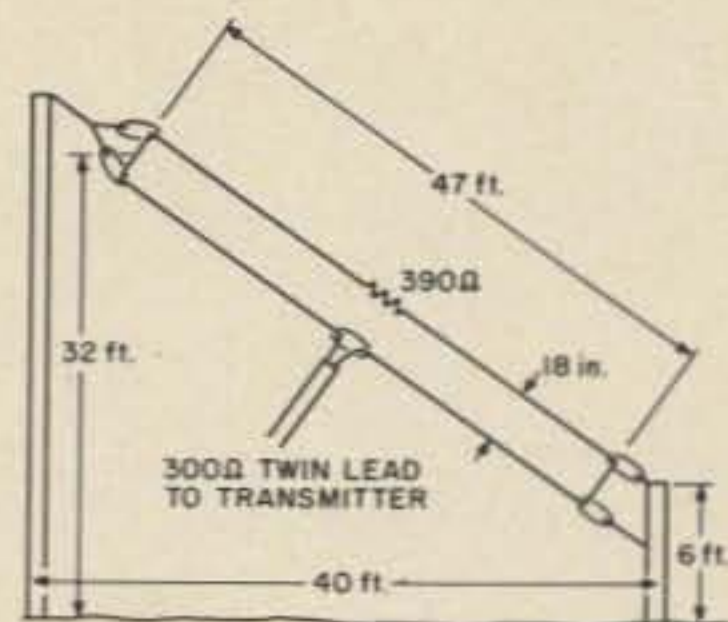

Fig. 2. 40-meter version of the T2FD antenna.

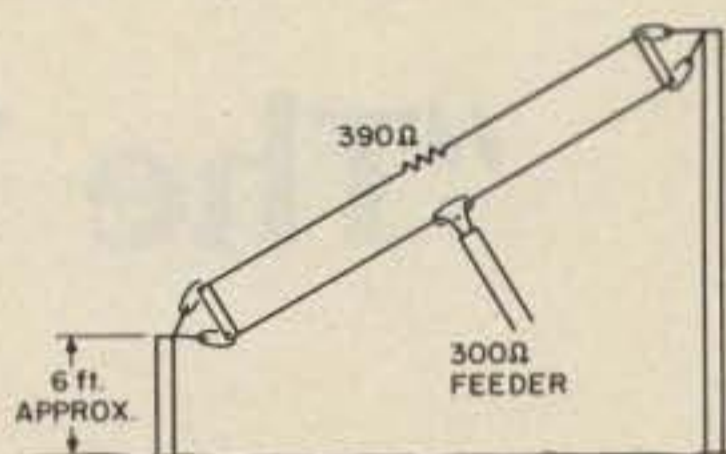

Fig. 3. Erect the antenna so that the angle of tilt is from 20 to 40 degrees for omnidirectional operation.

Basic design information is included on the drawing in case you may want to scale down this 80-meter version to 40 meters. If constructed as shown, this antenna will operate on all bands from 80 through 10 meters, including the new 30-meter band.

Feeding the Baby

The T2FD is best fed with an antenna tuner. Any balanced-output tuner that will match 300 Ohms to 52 Ohms should do fine. I am using a very uncomplicated home-brew tuner with excellent results. QRP can be very challenging and a lot of fun. This antenna will give good results with a minimum of space needed. Good luck, and I'll be looking for you on QRP CW. ■

T2FD Basic Design Data

1. The length of each leg from the center is equal to 50,000 divided by the lowest desired operating frequency (in kHz) and then multiplied by 3.28. The answer is in feet.
2. The spacing between radiating wires is equal to 3000 divided by the lowest desired operating frequency (in kHz) and then multiplied by 3.28. The answer is in feet.
3. The sloping angle for a nondirectional pattern should be of the order of 30 degrees.
4. The terminating resistor should be noninductive and have a rating equal to 35% of the transmitter input power.